

# 2003 INTERNATIONAL 420 CLASS RULES

Authority\*: International Sailing Federation  
Ariadne House, Town Quay, Southampton SO14 2AQ



\* The International Sailing Federation (ISAF) is not a National Authority (NA)

## Section A – GENERAL

### A.1 GENERAL INFORMATIONS

A.1.1 The International 420 Class Association **Class rules** are **closed class rules**.

A.1.2 The 420 is a one-design class. The intention of these rules is to ensure that the **boats** are as alike as possible in all respects affecting performance, in order that **crews** may compete against each other on level terms.

A.1.3 These rules are complementary to the Lines plan (plan de formes), the building specifications (Drawing N° 5), the International 420 Class Association (ICA) rudder blade drawing and the 420 International Measurement Form (IMF).  
The current issue of these official documents are listed on section H.  
These items, however complete, cannot anticipate every situation that may arise. If a point is not clearly covered, a ruling shall be obtained from the ISAF through the ICA technical Committee.

### A.2 LANGUAGE

A.2.1 The official language of the Class is English and in the event of dispute over interpretation, the English text shall prevail.

A.2.2 The word “shall” is mandatory and the word “may” is permissive.

### A.3 ABBREVIATIONS

|       |      |                                     |
|-------|------|-------------------------------------|
| A.3.1 | ISAF | International sailing Federation    |
|       | MNA  | ISAF Member National authority      |
|       | ICA  | International 420 Class Association |
|       | IMF  | 420 International Measurement form  |
|       | NCA  | National Class Associations         |
|       | ERS  | Equipment’s Rules of Sailing        |
|       | RRS  | Racing Rules of Sailing             |

### A.4 AUTHORITIES AND RESPONSABILITIES

A.4.1 The International authority of the class is the ISAF, which shall co-operate with the ICA in all matters concerning these **Class rules**.

A.4.2 Neither the ISAF, a National Authority, the ICA, a National Class Association (NCA), a **certification authority**, nor an **official measurer** is under no legal responsibility in respect of these **Class rules** or accuracy of measurement and no claim arising from them can be entertained.

### A.5 ADMINISTRATION OF THE CLASS

The Class is administered by the ICA, in conjunction with the ISAF. The ICA may delegate parts or all of its functions, as stated in these **Class rules**, to a MNA or a NCA.

### A.6 ISAF RULES

These **Class rules** shall be read in conjunction with the ERS. When a term is used in its defined sense, it is printed in **bold** type if defined in the ERS and in *italic* type if defined in the RRS.

## **A.7 AMENDMENTS TO CLASS RULES**

Amendments to these **Class rules** shall be proposed by the ICA and require to be approved by the ISAF.

## **A.8 INTERPRETATION OF CLASS RULES**

### **A.8.1 GENERAL**

Interpretation of **Class rules**, except as provided by A.8.2, shall be made by the ISAF in conjunction with the ICA. Request for an interpretation shall be made in accordance with the ISAF regulations.

### **A.8.2 AT AN EVENT**

Any interpretation of **Class rules** required at an event may be made by an international jury, constituted in accordance with the RRS appendix M. In this case, the jury shall consult the event chief measurer. Such interpretation shall only be valid during the event, and the organising authority shall, as soon as practical after the event, inform the ISAF and the ICA of such an interpretation.

## **A.9 INTERNATIONAL CLASS FEE AND INTERNATIONAL CLASS ASSOCIATION PLAQUE.**

**A.9.1** The ICA fee is 100 EURO per **boat** and shall be paid by the licensed builder to the treasurer of the ICA.

**A.9.2** The treasurer of the ICA, after having received the class fee, shall send to the licensed builder the ICA Plaque, with the **sail** number allocated to the **boat**.

**A.9.3** Licensed builders shall each year pay for a minimum of ten plaques to the treasurer of the ICA.

**A.9.4** The amount of the International Class Fee may be reviewed by the ISAF in consultation with the ICA.

**A.9.5** The ICA is responsible for the collection and distribution of the ICA fee.

## **A.10 CERTIFICATION AND MEASUREMENT CERTIFICATE**

**A.10.1** For a **hull** not previously certified, all items to be measured and to be in conformity with the Official documents shall be measured by an **official measurer**, and the details entered into the IMF which, when fulfilled, shall be supplied to the owner by the builder (a measurer shall not certify any part owned, designed or build by him, or in which he is an interested party, or has a vested interest, except where permitted by these **Class rules**).

**A.10.2** The IMF is necessary to obtain the Measurement **Certificate**. The Measurement **Certificate** is obtained as follow :

The IMF, together with any registration fee shall be send by the owner to the **certification authority** in the country where the **boat** is to be registered.

Upon receipt of a satisfactorily completed IMF and the fee, the **certification authority** issues the measurement **certificate** to the owner. The **certification authority** shall retain a copy of the IMF

## **A.11 VALIDITY OF THE MEASUREMENT CERTIFICATE.**

**A.11.1** A **certificate** is still valid after an alteration of the **corrector weights** only if the **hull** is re-weighed by an **official measurer** or an **event measurer**. When the **hull** is re-weighed, the measurer shall enter the details on the IMF and the Measurement **certificate**.

- A.11.2** A Measurement **certificate** becomes invalid upon :
- Change of ownership
  - Any important alteration or repair other than permitted routine maintenance to items required by the IMF to be measured.

## **A.12** RE-CERTIFICATION

- A.12.1** Upon change of ownership, the new owner shall apply to the certification **authority** where the **boat** will be registered for a new measurement **certificate**. The application shall include the old Measurement **certificate**, the IMF, and any registration fee that may be required. A new Measurement **Certificate** shall then be issued to the new owner.
- A.12.2** Upon alteration or repair to an item required by the IMF to be measured, the relevant item shall be re- measured by an **official measurer** and the details entered on the IMF. The owner shall apply for a new measurement **certificate** ( see A.12.1 for the procedure).

## **Section B – BOAT ELIGIBILITY**

For a **boat** to be eligible to race, the rules in this section shall be complied with.

### **B.1** CERTIFICATE

No **boat** is permitted to race in the Class unless the **crew** has a valid Measurement **Certificate**, in English or with English subtitles, including **corrector weight** details.

### **B.2** CERTIFICATION MARKS

Items that require **certification marks** shall be so marked.

### **B.3** CLASS MEMBERSHIP

The **crew** shall be current members of a NCA.

### **B.4** INTERNATIONAL 420 CLASS ASSOCIATION PLAQUE

The ICA Plaque shall be affixed to the **hull**, where specified in D.1.5

### **B.5** INTERNATIONAL 420 BUILDER'S PLAQUE

The builder's Plaque shall be affixed to the **hull**, where specified in D.1.5



## PART II – REQUIREMENTS AND LIMITATIONS

### Section C – CONDITIONS FOR RACING

#### C.1 MEASUREMENT

Measurement shall be carried in accordance with the ERS.

#### C.2 CREW

##### C.2.1 RESPONSIBILITY OF THE CREW

It is the **crew's** responsibility to ensure that her **boat** and his **personal equipment** comply with the **Class rules** during races.

##### C.2.2 LIMITATIONS

C.2.2.1 The **crew** shall consist of two persons, each in contact with the **boat**.

C.2.2.2 No **crew** member shall be substituted during an event without the approval of the Race Committee.

##### C.2.3 PERSONAL EQUIPMENT.

C.2.3.1 RRS 43.1 shall apply, with the amendment that each **crew'** member's **personal equipment** shall weigh 9 kg maximum, including footwear and clothing worn below the knees but excluding the trapeze harness.

C.2.3.2 As an alteration to RRS 49.1, a trapeze may be used, but only one member of the **crew** shall use a trapeze harness. The trapeze harness shall not be filled with **ballasts**, shall float, and shall have a maximum weight of 4 kg (Weight shall be determined as required by RRS Appendix H).

#### C.3 ADVERTISING

##### C.3.1 CATEGORY

Advertising is permitted in accordance with the ISAF RRS Appendix I : ISAF Advertising code 20.3.2(b) [category C] excepted as amended by C.3.2.



##### C.3.2

Advertising is permitted only in following positions (see diagram 1):

###### (a) Event advertising :

Hull : the outside hull shell between 600 mm and 1650 mm from the foremost point (fittings excluded)

###### (b) Competitor advertising :

Hull : the outside hull shell aft of 1650 mm from the foremost point (fittings excluded)

Mainsail : below sail numbers

Spinnaker : on one side of the sail below sail numbers.

#### C.4 SAFETY EQUIPEMENT

C.4.1 Each **crew** member shall wear while afloat a fastened **personal buoyancy**, officially approved by the Authority in charge of the certification in their country.

- C.4.2** Hand hole covers and drainage plugs shall be kept in place while afloat.
- C.4.3** The **boat** shall be fitted with a floating painter line rope of a minimum length of 8 meters and minimum diameter of 8 mm, securely attached to the **mast**, and which can be grasped at the foremost stem (even if capsized) from a rescue boat.

**C.5. BOAT**

**C.5.1 WEIGHT**

The **boat** fully rigged for sailing and in dry conditions, but without **sails** and **personal equipment** shall have a minimum weight of 100 kg.

**C.5.2 FLOTATION**

- C.5.2.1** The **boat** shall have two side buoyancy tanks and one in the front. At the first measurement, the measurer shall check the watertightness of the buoyancy tanks, inspection ports and drain plugs. If the buoyancy is unsatisfactory, the measurer shall not sign the IMF until successful remedial measures have been taken. There after, it is the responsibility of the competitor/owner to ensure the watertightness of these.

**C.6 HULL**

**C.6.1 IDENTIFICATION DURING RACES**

The outside **hull** shell between the foremost point and 600 mm from the foremost point shall be intend only for the boat identification if specified in the Sailing Instructions, or shall be without advertising if nothing is specified in the sailing instructions (see diagram 1)

**C.6.2 FITTINGS**

(for information : are listed in this paragraph the fittings which are removed by the teams at the end of the races, sheets or mast wedges for example, or replaced when out of order like the centreboard flap devices)

The **rigging** and fittings listed hereunder shall be fitted and used only as specified. Except when mentioned, the direction of the control lines, sheets, and ropes shall not be modified by means of shackles, rings, loops thimbles or holes in the **boat**. Fittings listed hereunder shall comply with the current **Class rules**.

**C.6.2.1 MANDATORY**

- C.6.2.1.1** Mainsail, headsail and spinnaker sheets.

- C.6.2.1.2** Four single sheaves blocks for the mainsheet. One may be a ratchet block. The mainsheet shall be attached on an attachment on the block which is connected to the bridle. Two blocks shall be attached directly to the boom. The fourth block shall be fixed to a mounting on the aft part of the centreboard case capping or keelson. While racing, the four blocks shall be used to obtain the 4 / 1 purchase.

- C.6.2.1.3** A bridle made of two equal strops, either of rope or wire, attached to the outer ends of the mainsheet bar/track or its end fittings, and to the mainsheet block, so forming a triangle. Each strop may be adjustable by including one additional eyelet and one snaphook fixed at the outends of the track/bar or its end fittings. Any other adjusting system is prohibited.

- C.6.2.1.4** One kicking strap of rope or stainless steel wire with a maximum of five blocks. Supplementary fitting for the kicking strap is mentioned in D.5.2.6.

**C.6.2.2 OPTIONAL**

In addition to the fittings listed above, the following fittings may be fitted, and if fitted shall be used only as specified :

- C.6.2.2.1 Wedges to control the bend of the mast.
- C.6.2.2.2 One suction bailer to evacuate water.
- C.6.2.2.3 Toes traps for the **crew**, adjustable by means of ropes and knots or one cleat without moving parts and one length of shockcord to keep them lifted up.
- C.6.2.2.4 One device attached to or in front of the stemhead fitting as spinnaker sheet guard to prevent the spinnaker sheet to slip under the **boat**.
- C.6.2.2.5 One hook on each side of the boat, on shrouds/shroud plates or fixed on the deck and at 100 mm maximum forward of the centre of the hole of the shroud plates, to keep the spinnakers sheets clear of the trapeze.
- C.6.2.2.6 One device on each side of the boat for securing the spinnaker halyard while the spinnaker is not set.
- C.6.2.2.7 Two tubes made of plastic or other material at the lower end of shrouds and one for the lower end of the forestay or their adjusters to ease the passage of the sheets and to prevent snagging.
- C.6.2.2.8 Stainless steel springs under blocks to prevent these one falling over.
- C.6.2.2.9 One non electrical wind indicator at the **mast** head.
- C.6.2.2.10 Two **centreboard** flap devices made of plastic or rubber.
- C.6.2.2.11 One magnetic compass (electronic devices not permitted) fixed to a mounting bracket. The compass shall not recess into either side tank or deck. The mounting bracket may be attached on the **mast** or may be used to close the mast gate.
- C.6.2.2.12 Chaffing and or filler strips, of any material except metal, may be fixed in the centreboard case and rudder head in order to prevent the movement of the **centreboard** and **rudder** blade.
- C.6.2.2.13 A moulded insert in the thwart or a device to secure the **spinnaker pole** in the cockpit.

## C.7 SAILS

### C.7.1 MAINTENANCE

- C.7.1.1 Routine maintenance such as repairs of tears is permitted without re-measurement and re-certification. Altered **sails** shall be re-measured and the **official measurer** shall place a new **certification mark** on the **sail** with the new date of **fundamental measurement**

### C.7.2 LIMITATIONS

- C.7.2.1 Not more than one mainsail, one jib and one spinnaker shall be carried aboard.
- C.7.2.2 Not more than one mainsail, one jib and one spinnaker shall be used during an event, except when mentioned in the Sailing Instructions or except when a **sail** has been lost or damaged beyond repair. Such replacement may be made only with the approval of the race committee.

### C.7.3 MAINSAIL

#### C.7.3.1 Identification

Identification shall comply with RRS 77 except when mentioned hereunder :

As an alteration to RRS Appendix G 1.3 (a), the following items shall be positioned on each side of the **sail** as follow :

- (a) National letters above and below and adjacent to the second batten from the top, port and starboard not overlapping each other, those on starboard side being uppermost .

- (b) **Sail** numbers above and below and adjacent to the third batten from the top, port and starboard not overlapping each other, those on starboard side being uppermost.

Numbers and letters shall be in red, of a minimum width of 200 mm (except number 1 and letter I), of a minimum thickness of 45 mm and of a minimum height of 300 mm. Other dimensions and indications regarding letters and numbers are specified in RRS Appendix G 1.2

All numbers, letters and the emblem shall be of paint or securely attached.

#### **C.7.3.2** Use

**C.7.3.2.1** The **sail** shall be hoisted on a halyard. The arrangement shall permit hoisting and lowering of the **sail** while afloat.

**C.7.3.2.2** The highest visible point of the **sail**, projected at 90° to the **mast spar**, shall not be set above the **upper point**. The lowest visible point of the **sail**, projected at 90° to the **mast spar**, shall not be set under the **lower point**. The intersection of the **leech** each extended as necessary, shall not be, on the boom, behind the **outerpoint**.

**C.7.3.2.3** **Luff** and **foot** bolt ropes shall be in the **spar** grooves or tracks.

#### **C.7.4** **JIB**

##### **C.7.4.1** Identification

As an alteration to RRS G.1.3 (e), identification on the headsail is not mandatory.

##### **C.7.4.2** Use

The **sail** shall be hoisted on a halyard. The arrangement shall permit hoisting and lowering of the **sail** while afloat.

#### **C.7.5** **SPINNAKER**

##### **C.7.5.1** Identification

Identification shall comply with RRS 77, except when mentioned hereunder :

As an alteration to RRS Appendix G 1.3 (d), national letters are optional.

If positioned, national letters may be in line with the **sail** numbers. The colour of letters and numbers is optional, but they shall be all of the same colour, full painted, and shall contrast with the colour of the panel to which they are positioned, of a minimum width of 200 mm (except number 1 and letter I), of a minimum thickness of 45 mm and of a minimum height of 300 mm. Other dimensions and indications regarding letters and numbers are specified in RRS Appendix G 1.2 and G 1.3 (d).

All numbers and letters shall be of paint or securely attached. Numbers and letters if on both side shall not overlap and shall be placed at different heights with a minimum of space of 60 mm.

##### **C.7.5.2** Use

The **sail** shall be hoisted on a halyard. The arrangement shall permit hoisting and lowering of the **sail** while afloat.

## **Section D – HULL AND DECK**

### **D.1** CERTIFICATION

**D.1.1** Only an **official measurer** shall measure the **hull** and the deck, and sign the declaration on the IMF that they comply with the **Class rules**, lines plan and building specification (Drawing 5). Measurements to ensure the conformity of the **hull** and the deck are specified on the IMF but the intention is that beyond these measurements, the **hull** shall be completely conform to the Official Documents.



**D.1.2** To be certified in conformity with the **Class rules**, Lines Plan and Building specification (Drawing N° 5) the **hull** and the deck shall comply with the official documents **in force** at the time of initial **fundamental measurement**.

**D.1.3** Measurement shall be carried out in accordance with the ERS.

**D.1.4** Templates used for **fundamental measurement** of **hull** and deck shall be supplied by the ISAF. Tolerances are only given to allow minor building errors and shall not be deliberately used to alter the design. The **boat**, before leaving the builder's premises shall be measured by an **official measurer**. The measurer shall report on the IMF that he considers being a departure from the intended nature and design of the **boat**, and the Measurement **Certificate** may be refused.

**D.1.5** No **boat** shall leave the builders' premise without the ICA plaque and the builder's plaque affixed. The builder's Plaque shall mention :

- The trade mark of the **boat**
- The name and the address of the builder
- The year of building.

The ICA plaque shall mention:

- The ISAF logo
- The ICA logo
- The **sail** number allocated to the boat

The ICA plaque shall be affixed on the starboard side tank, close to the transom and the builder's plaque on the inside transom (see rule B.4 and B.5)

## **D.2**      **MANUFACTURERS**

**D.2.1** International 420 **hulls** shall be moulded and assembled only by licensed builders. Application for a licence shall be made to the ISAF which shall consult with the ICA and the MNA of the country where the builder has its yard before granting a licence. Hulls and decks shall be supplied only as permanently assembled boat units. **Rigs, sails, hull appendages** and fittings may be produced by any manufacturer

**D.2.2** Licensed builders have the sole responsibility that their production moulds, plugs and assembled boats comply with the current **Class rules** and official documents.

**D.2.3** If a builder does not comply with the requirements quoted in the Class rules and the Official documents, the ISAF can revoke the Licence on the recommendation of the ICA.

**D.2.4** If a builder is found to have supplied a **boat** that does not comply with the rules in application, he shall be liable to rectify the error, and may have his licence as a builder withdrawn.

## **D.3**      **BUILDING AND MATERIALS FOR BUILDING**

**D.3.1** The **boat** shall be build in conformity with the building specifications (Drawing N° 5)

**D.3.2** Materials used for building shall be those specified on the Building specification (Drawing N°5).

**D.3.3** No less than 0.05m<sup>3</sup> of positive buoyancy shall be securely attached in each buoyancy side tank to give approximately equal buoyancy laterally and longitudinally. The buoyancy shall be of closed cell rigid foam or air containers of not less than two litres. It shall not be used as reinforcement.

**D.3.4** Control lines, ropes, sheets, halyards shall not pass through the buoyancy tanks and the breakwater.

**D.4 DIMENSION AND MEASUREMENT.**

**D.4.1** For **boats** built after the first of January 2005, to check the **boat**, a base line shall be fixed at 200 mm below the **Hull datum point** and 92 mm below the keel at 3780 mm from the **Hull datum point**.

**D.4.2** All measurements carried out from the **Hull datum point** shall be made parallel to the baseline and depth measurement perpendicular to the base line. Measurement sections shall be perpendicular to the base line.

**D.4.3** The **hull length**, shall be minimum 4180 mm and maximum 4220 mm.

**D.4.4** Measurement sections 2,5,8 shall be at 780 mm, 1980 mm and 3180 mm from the **Hull datum point** (see diagram 2).

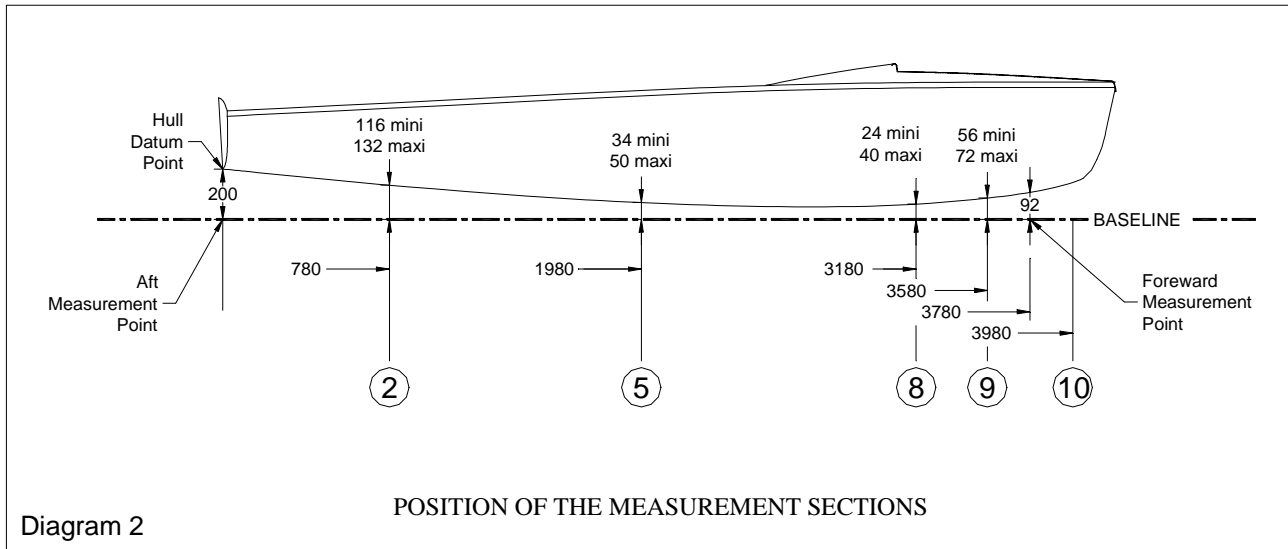

**D.4.5** Section templates shall be applied as shown on the measurement diagram 3. The top of the deck, at the **sheerline** shall not be more than 10 mm above or below the sheer marks on the templates. The gunwale rubbing strakes shall touch the templates or clear by. Below the line 1, the templates shall touch the **hull** or clear by not more than 16 mm, and the difference between the greatest and least clearance shall not exceed 12 mm.

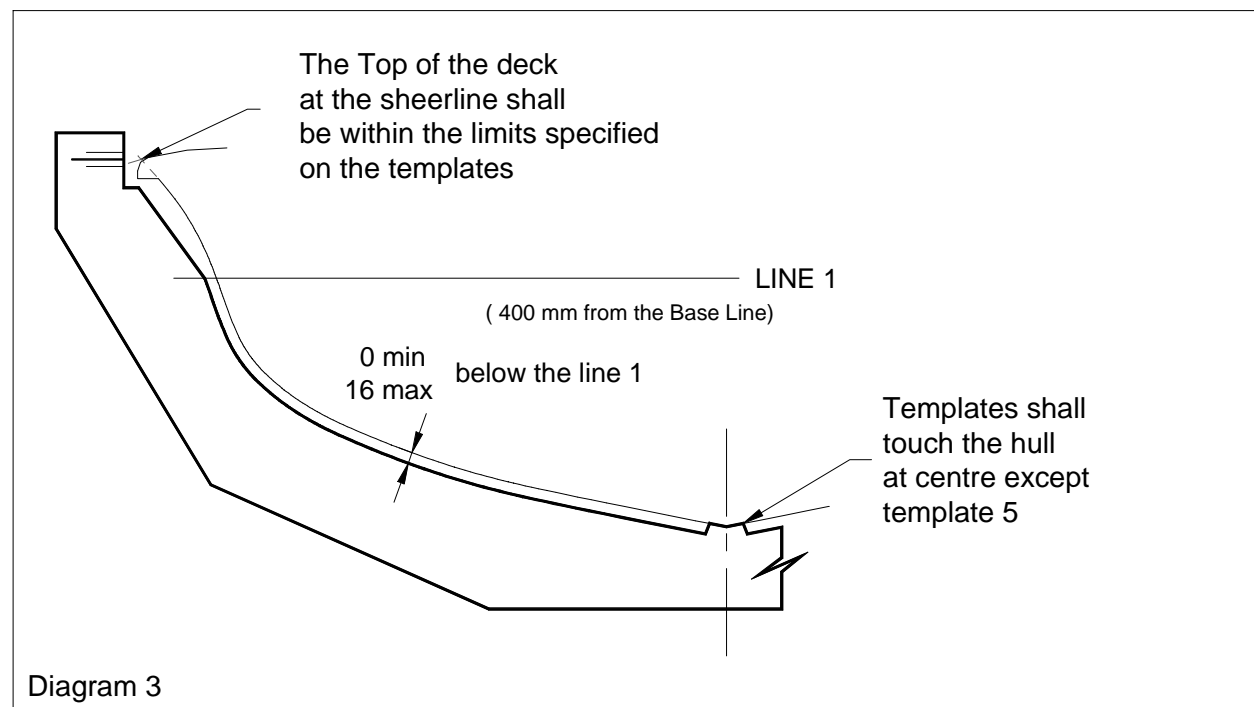

**D.4.6** If the measurer has a doubt regarding the conformity of the **hull** to the lines plan, the hull may be checked at measurement sections 3, 4, 6, 7, 9 or/and 10. The distances from these sections to the **Hull datum point** are specified on the Drawing N° 5 and the lines plan.

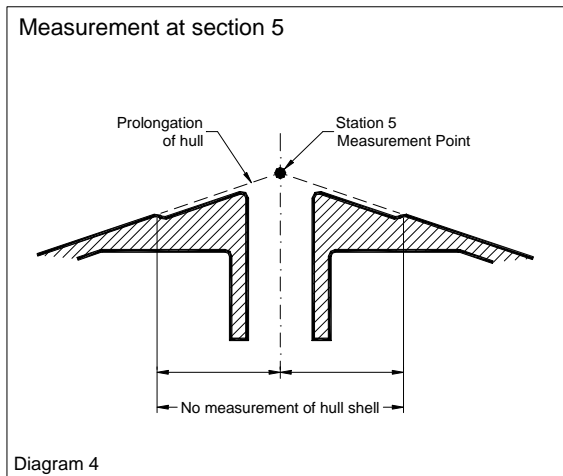

**D.4.7** To check the profile of the keel, the distances between the base line and the keel shall be within the limits specified on the measurement diagram 2.

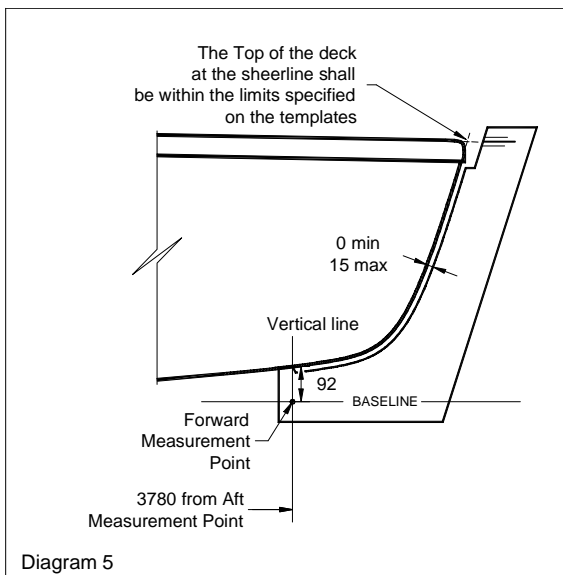

**D.4.8** The stem template shall be applied as shown on the measurement diagram 5. The template shall touch the stem or clear by not more than 15 mm.

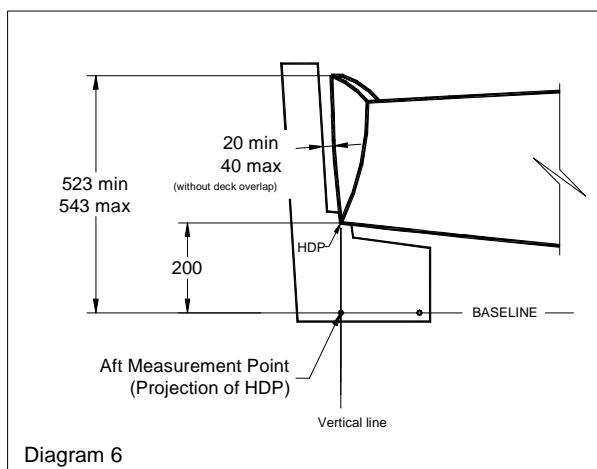

**D.4.9** The transom template shall be applied as shown on the measurement diagram 6. The distance between the transom and the template shall be minimum 20 mm and maximum 40 mm except at the deck overlap.

**D.4.10** The transom radius shall be checked in a horizontal plan located 400 mm above the baseline. On each side, the curvature measured at 520 mm from the centreline shall be 26 mm minimum and 42 mm maximum (see measurement diagrams 7 and 8).

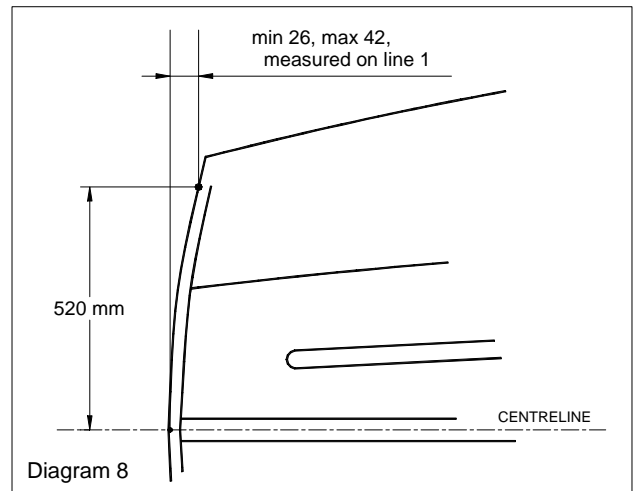
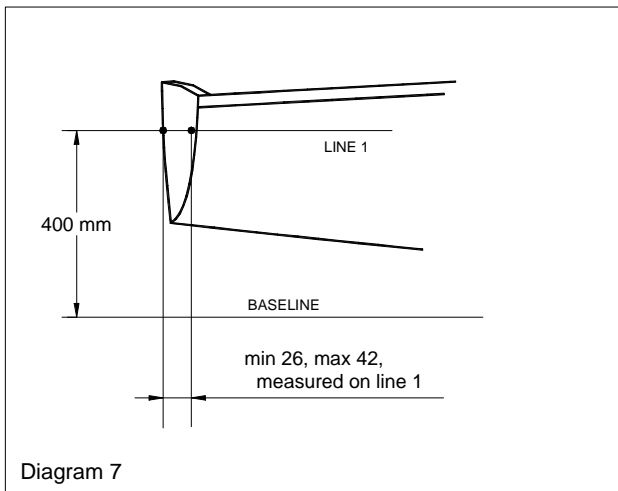

**D.4.11** The centreboard case shall be in the position shown on the measurement diagram 9 and the Drawing N° 5. The forward upper part of the centreboard case shall not be less than 330 mm above the underside of the hull, and the aft upper part shall not be less than 295 mm above the underside of the hull. Overall, the centreboard capping shall be maximum 170 mm width.

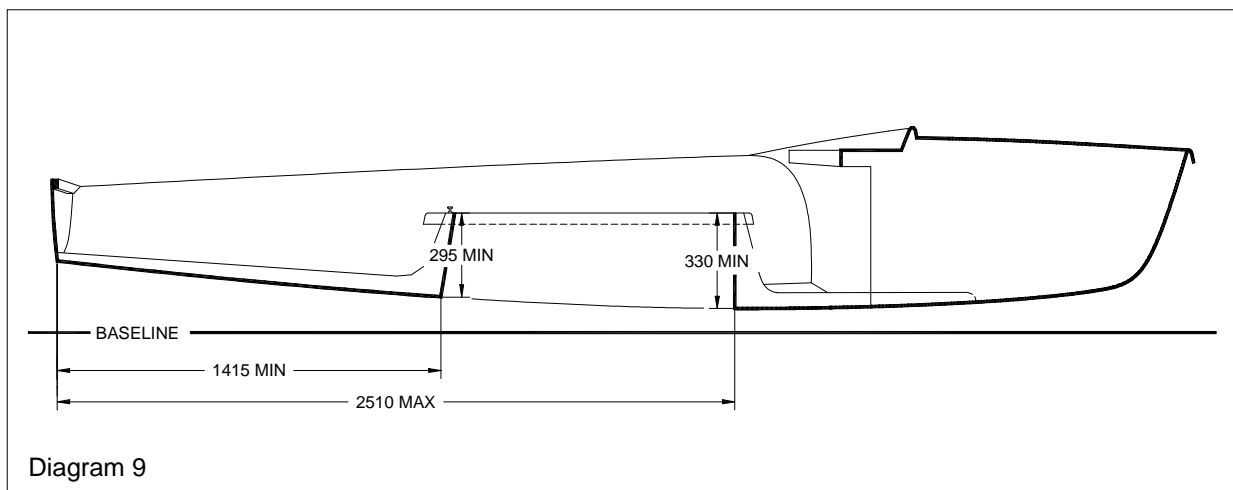

**D.4.12** The boat shall conform to all the dimensions specified on the drawing n° 5.

**D.4.13** The convex curve of the foredeck shall be measured by placing a 300 mm straight edge on any part of the deck forward of the breakwater. In any plane the straight edge must not be flat against the surface of the deck.

**D.5** **ASSEMBLED HULL**

(For information : In the following rules 5.1 and 5.2, are listed all the fittings mentioned on the Drawing 5, with the use and the position and which shall be checked during the **fundamental measurement**. Also the fittings directly fixed on the **hull** by the builder are mentioned).

**D.5.1** **FITTINGS WITH A POSITION OR A DIMENSION SPECIFIED**

The following fittings shall be positioned in accordance with the drawing N°5 and shall be used as specified

**D.5.1.1** One stemhead fitting to attach the forestay and the **headsail**. The centre of the front hole of the stemhead fitting shall be at 4085 mm minimum and 4125 mm maximum from the **Hull Datum Point**. Only one hole for the forestay and one hole for the **headsail** are allowed, and the forestay shall be attached to the front hole, the **headsail** shall be attached to the aft hole.

- D.5.1.2** Two shroud plates for the shrouds, on each side of the **boat**. The centre of the hole of the shroud plates measured on the centreline shall be at 2550 mm minimum and 2570 mm maximum from the **Hull Datum Point**.
- D.5.1.3** One mainsheet track or bar of any profile, made only of metal or GRP. It shall be straight and fixed to the centreboard case capping. The track or bar shall have a maximum thickness of 40 mm and a maximum width of 40 mm. The centreline of the track or bar shall be fixed to the side tanks at 1400 mm minimum and 1500 mm maximum from the **Hull Datum Point**.
- D.5.1.4** One mast step fixed on the keelson. The length of the **mast** step shall be 150 mm maximum. The forward part of the **mast** step shall be at 2890 mm minimum and 2910 mm maximum from the **Hull Datum Point**. The bearing surface of the **mast** step shall be at any point at 45 mm minimum and 65 mm maximum from the outside surface of the **hull**.
- D.5.1.5** Two headsail fairleads fixed directly to the buoyancy tanks, the measurement point of which shall be at 2020 mm minimum and 2120 mm maximum from the **hull datum point** and 625 mm minimum from the centreline. The fairleads shall be fixed directly to the buoyancy tanks (see diagram 10).

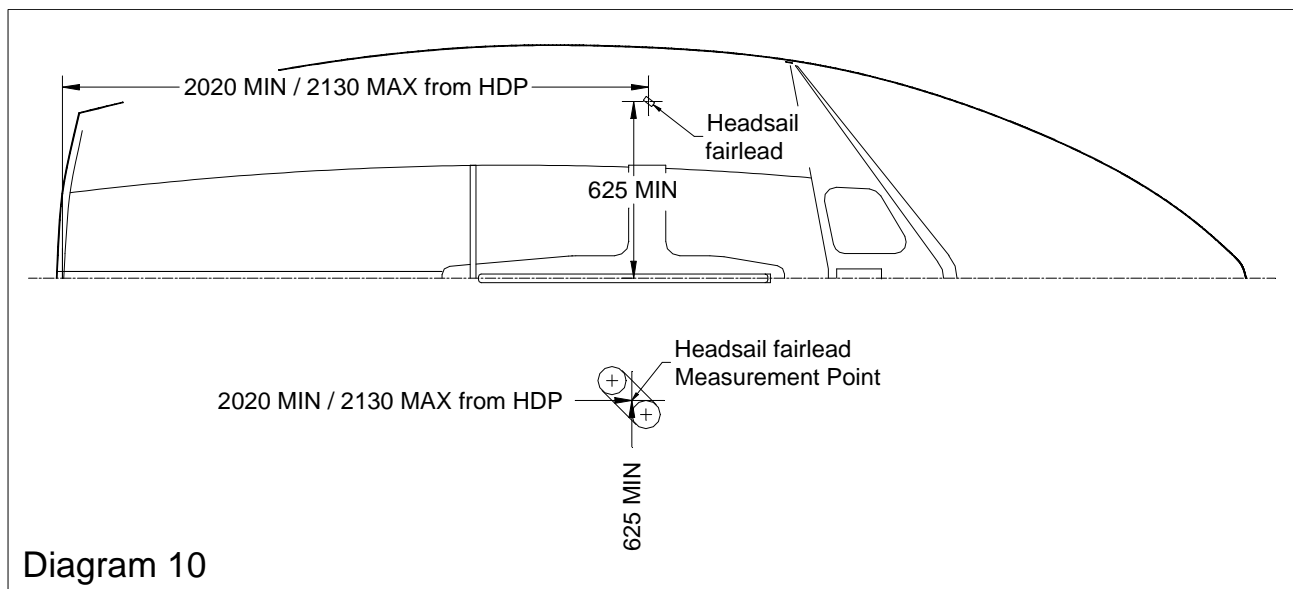

- D.5.1.6** Two spinnaker fairleads or blocks for the spinnaker sheets fixed at 1950 mm maximum from the **Hull Datum Point**.
- D.5.1.7** One drainhole in each buoyancy tank, located near the transom, with a minimum dimension of 15 mm and maximum dimension of 25 mm.
- D.5.1.8** A minimum of one inspection hole for each buoyancy tank with a minimum diameter of 100 mm.
- D.5.1.9** Two spinnaker bags located according to the Drawing 5.
- D.5.1.10** One at least draining hole in the transom, with a total maximum surface of 80 cm<sup>2</sup>. The closing system is optional.

**D.5.2 FITTINGS WITHOUT A POSITION SPECIFIED**

The **rigging** and fittings listed hereunder shall be fitted and used only as specified. Cleats mentioned in these rules, may incorporate a hook or an overcleat fairlead. A cleat wedge under each cleat is permitted. Except when specified, the direction of the control lines, sheets and ropes shall not be modified by means of shackles, rings, loops or holes in the **boat**.

- D.5.2.1** Two pintles or two gudgeons for the **rudder**.

- D.5.2.2 One swivelling cleat with moving part fixed on the aft part or the **centreboard** case capping or two cleats with moving parts on the side tanks for the mainsheet.
- D.5.2.3 Two cleats with moving parts, fixed on the side tanks, for the headsail sheets.
- D.5.2.4 Two cleats without moving parts, fixed on the side tanks, for the spinnaker sheets.
- D.5.2.5 One fairlead and one cleat with or without moving parts for the spinnaker halyard.
- D.5.2.6 One cleat without moving parts and one guiding block directly behind the cleat for the kicking strap system. Additional fitting for the kicking strap is mentioned in C.6.2.1.4.
- D.5.2.7 One cleat without moving parts and one guiding block directly behind the cleat for the spinnaker uphaul/downhaul system (adjusting the height of the spinnaker boom). An additional block, a rope and a device to attach the rope is permitted between the mast and the cleat mentioned above. Mast fitting for the spinnaker boom uphaul/downhaul is mentioned in F 2.5.13.

### D.5.3 **WEIGHT**

The **hull**, including stemhead fitting, shrouds plates, headsail and spinnaker fairleads, cleats and blocks, toestraps, rudder pintles and gudgeons, mainsheet track/bar, inspection hull covers, spinnaker bags, **corrector weights** maximum 2 kg, but excluding the **centreboard**, the control lines, the rudder and the towing rope shall be 80 kg minimum.

### D.5.4 **HULL CORRECTOR WEIGHTS**

If the **hull** is found to weigh less than 80 kg, correctors, total weight of maximum 2 kg shall be bolted to the upper inside of the transom. The number and total of correctors shall be recorded on the International Measurement Form and the Measurement Certificate. Correctors shall not be removed or altered without the **boat** being re-weighed by an **official measurer** or an **event measurer**.

## **Section E - CENTREBOARD, RUDDER AND TILLER**

### E.1 **MEASUREMENT**

**Centreboard** and **rudder** shall comply with the current **Class rules**.

### E.2 **LIMITATIONS**

Only one centreboard and one rudder blade shall be used during an event except in case of loss or damage beyond repair. Such replacement may be made only with the approval of the race committee.

### E.3 **CENTREBOARD**

E.3.1 The profile of the **centreboard** shall conform to the dimensions and tolerances specified on the measurement diagram 11.

E.3.2 The centreboard shall be on even thickness (minimum 16 mm and maximum 20 mm) throughout, except that the edges may be bevelled to a maximum distance of 105 mm from the edges.

E.3.3 The **centreboard** shall be made only of wood or plywood or GRP. If of wood or plywood a GRP coating is permitted. If of GRP, a foam core is permitted.



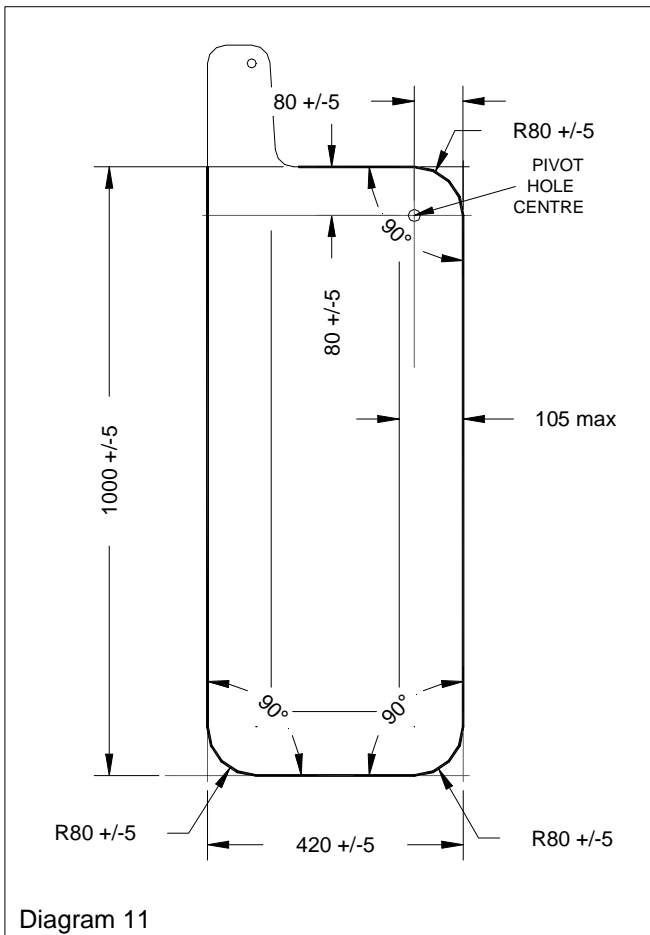

**E.3.4** The **centreboard** shall be fitted by means of an axis pin throughout a hole in the centreboard case. When fully raised, no part of the centreboard shall project below the hull surface.

**E.3.5** Only the following fittings are permitted :

(a) One centreboard uphaul of rope using three single blocks and two cleats without moving parts. A cleat wedge is permitted under the cleats.

(b) One centreboard downhaul of rope and/or elastic and one cleat without moving parts. A wedge is permitted under the cleat.

**E.3.6** The direction of the control ropes used for the adjustments of the centreboard shall be modified only by means of the blocks mentioned in the rule E.3.5.

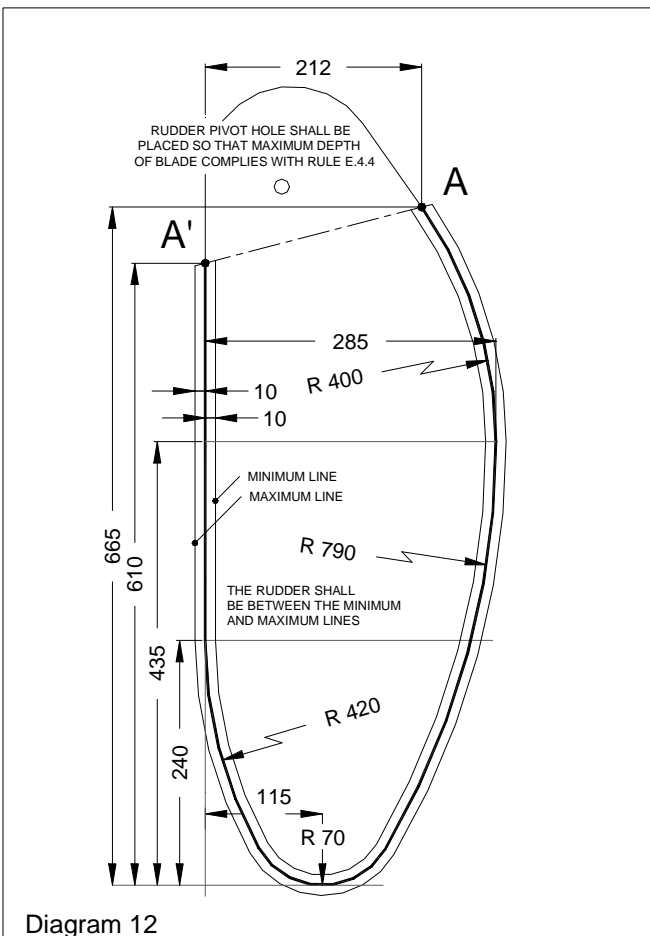

## E.4 RUDDER

**E.4.1** The profile of the rudder blade shall conform to the dimensions and tolerances specified on the Diagram 12 (or the official 420 rudder blade drawing - April 1986)

**E.4.2** The rudder blade shall be of even thickness (minimum 16 mm and maximum 20 mm) throughout, except that the edges may be bevelled to a maximum distance of 105 mm from the edges

**E.4.3** The rudder head shall be made of metal and the tiller of wood or aluminium alloy. The rudder blade shall be made only of wood or plywood or GRP. If of wood or plywood a GRP coating is permitted. If of GRP a foam core is permitted.

**E.4.4** No part of the rudder blade, when fully lowered, shall extend more than 540 mm below the hull. The leading edge of the rudder blade shall not be forward a vertical line through the **Hull Datum Point** (see measurement diagram 13).

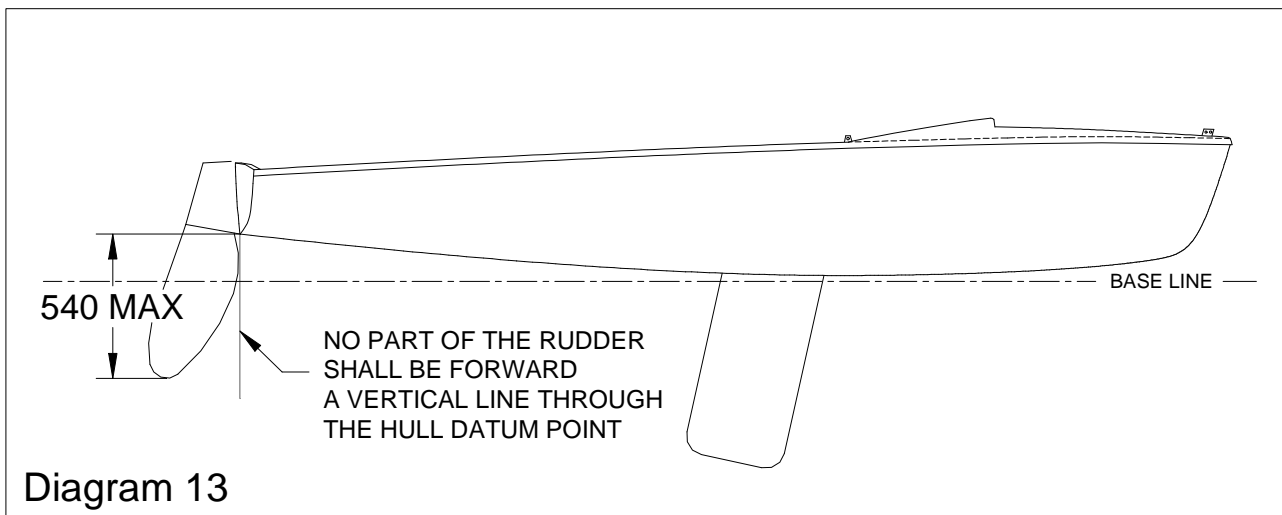

**E.4.5** Only the following fittings are permitted :

- (a) One rudder downhaul made of one stainless steel wire and/or rope and elastic and on the tiller one cleat without moving parts (a wedge under the cleat is permitted), or a pin or bolt through the rudder head and rudder blade to hold the rudder blade down.
- (b) One tiller extension, which may be adjustable or telescopic type, of any material.
- (c) One universal joint between tiller and extension.

**E.4.6** A safety device shall be fitted so that the **rudder** cannot separate from the **hull** during a capsize.

## Section F - RIG

### F.1 MEASUREMENT

Measurement shall be carried out in accordance with the ERS.

### F.2 MAST

#### F.2.1 MEASUREMENT

The **mast** and its fittings shall comply with the current **Class rules**.

#### F.2.2 MANUFACTURER

Manufacturer is optional.

#### F.2.3 MATERIALS

The **mast** shall be of aluminium alloy. It may be anodised.

#### F.2.4 CONSTRUCTION

The **mast** shall include a fixed sail groove or track, which may or may not be integral with the **spar** but shall be of the same material.

#### F.2.5 FITTINGS

The following fittings are mandatory and shall be used :

**F.2.5.1** A **mast** head fitting.



- F.2.5.2** One halyard for the mainsail, one halyard for the headsail and one halyard for the spinnaker. The end of the spinnaker halyard may be fitted with a shockcord. The direction of the halyards shall be modified only by means of the blocks or fairleads specified in the Class rules.
- F.2.5.3** One halyard lock at the mast head for the mainsail or one halyard lock/rack below the gooseneck.
- F.2.5.4** Fairleads or sheaves for each of the mainsail and the headsail halyards. The headsail halyard sheave or fairlead shall be located below the forestay attachment. The lower edge of the headsail halyard, when intersecting the mast at 90 degrees, shall be at 4520 mm minimum from the **heel point**.
- F.2.5.5** One fairlead or sheave for the spinnaker halyard. The extension of the line of the top of the spinnaker halyard, when held taut at right angles to the mast, shall intersect the foreside of the mast at 4650 mm maximum from the **heel point**. If led through an eye or block, no part of such eye or block shall project more than 40 mm from the foreside of the mast.
- F.2.5.6** Fittings to secure the shrouds, forestay and trapeze wires to the mast so that their lines intersect the mast at 4550 mm minimum and 4650 mm maximum from the **heel point**.
- F.2.5.7** One set of fixed **spreaders** at 2550 mm minimum and 2650 mm maximum from the **heel point**. **Spreaders** may be adjusted telescopically for length and retained with screws or pins, and fore and aft by adjustment screws and linkage levers. **Spreaders** shall not be adjustable when racing.
- F.2.5.8** One gooseneck fixed to the **mast** to connect the boom to the **mast**.
- F.2.5.9** One cleat without moving parts below the gooseneck for the Cunningham line.
- F.2.5.10** A tensioning system for the **headsail** halyard made with 2 blocks of not more than six sheaves and one cleat. The system shall be attached via a hook or a fork to the headsail halyard at the other end to the mast or mast step. The cleat may have moving parts and shall be attached to either of the two blocks. Enclosed purchase systems such as power boxes are not permitted.
- F.2.5.11** Ropes or devices around the **mast** and through the **tack** cringle to secure the **sail**.
- F.2.5.12** A protection around the **mast** where it touches the mast gate (maximum Height / thickness = 150 mm/ 5 mm).
- F.2.5.13** One spinnaker boom uphaul /downhaul made of rope and shockcord and one hook. The spinnaker boom uphaul/downhaul may be fitted with two plastic balls. For the adjustment of the spinnaker boom uphaul/downhaul, only the following fitting is allowed : one eye or block on the foreside of the **mast**, located below the forestay and shroud attachment. One eye or block or one hole in the mast partner at the foreside of the **mast** at the level of the mast partner. One block or one fairlead at the bottom of the mast. (Additional fitting for the spinnaker boom uphaul/downhaul is mentioned in D.5.2.7).
- F.2.5.14** One kicking strap attachment.
- F.2.5.15** One spinnaker boom fitting on foreside of the mast.
- F.2.5.16** A mast heel fitting which may include the sheaves for the halyards and spinnaker boom uphaul/downhaul.
- F.2.5.17** Rotating and permanently bent masts are prohibited but a set due to distortion of not more than 40 mm is permitted.



## F.2.6 DIMENSIONS

|                                                                        | minimum | maximum |
|------------------------------------------------------------------------|---------|---------|
| Mast length                                                            |         | 6260 mm |
| Fore and aft dimension between 1550 mm and 4500 mm from the heel point | 50 mm   | 75 mm   |
| Transverse dimension within 4500 mm from the heel point                | 45 mm   | 75 mm   |
| Sail limit marks width                                                 | 10 mm   |         |
| Lower point height (from the heel point)                               | 1160 mm |         |
| Upper point height ( from the heel point)                              |         | 6060 mm |

## F.2.7 WEIGHT

**Mast weight**, fittings specified in F.2.5 (except the tensioning system mentioned in F 2.5.10 and the supplementary block between the mast and the cleat mentioned in F2.5.13) and **rigging** specified in F6.1 included, shall be minimum 7.5 kg.

**F.2.8** The centre of gravity of the **mast**, including fittings and rigging listed in F.2.7, with the rigging and trapeze wires secured along the **mast**, shall be not less than 2400 mm from the lowest point of the **mast**.

## F.3 BOOM

### F.3.1 MEASUREMENT

The **boom** and its fittings shall comply with the current **Class rules**.

### F.3.2 MANUFACTURER

Manufacturer is optional.

### F.3.3 MATERIALS

The **boom** shall be of aluminium alloy. It may be anodised.

### F.3.4 CONSTRUCTION

**F.3.4.1** The **boom** shall include a fixed **sail** groove or track, which may or may not be integral with the **spar** but shall be of the same material.

**F.3.4.2** The **boom** shall be made from an uniform section and shall not be tapered.

### F.3.5 FITTINGS

#### F.3.5.1 MANDATORY

**F.3.5.1.1** A kicking strap attachment (eye, plate, or hole trough the **boom**).

**F.3.5.1.2** Two mainsheet attachments (eyes, plates, or holes trough the **boom**).

**F.3.5.1.3** A gooseneck attachment.

**F.3.5.1.4** One end fitting which may incorporate one sheave. One outhaul consisting of a rope, a shockord, one block and one cleat without moving parts. A guiding block directly behind the cleat may be used.

#### F.3.5.2 OPTIONAL

**F.3.5.2.1** Ropes or devices through the cringles and around the boom to secure the **sails** at the **clew point** and the **tack point**.

**F.3.5.2.2** Protections where the boom touches the shrouds, of any material (maximum length/height/thickness = 100 mm/30 mm/5 mm).

### F.3.6 DIMENSIONS

|                                    | minimum | maximum |
|------------------------------------|---------|---------|
| Vertical boom spar cross section   | 55 mm   | 89 mm   |
| Transverse boom spar cross section | 76 mm   | 32 mm   |
| Sail limit mark width              | 10 mm   |         |
| Outer point distance               |         | 2400 mm |

### F.4 SPINNAKER POLE

#### F.4.1 MEASUREMENT

The **spinnaker pole** and its fittings shall comply with the current **Class rules**

#### F.4.2 MANUFACTURER

Manufacturer is optional

#### F.4.3 MATERIALS

The spinnaker pole shall be made of metal or GRP.

#### F.4.4 FITTING

Only the following fitting is permitted :

- (a) End fittings and control line
- (b) Fittings approximately at the mid point for attachment for uphaul/downhaul.

#### F.4.5 DIMENSIONS

The maximum length of the **spinnaker pole** is 1750 mm.

### F.5 RIGGING AND FITTING

#### F.5.1 RIGGING

The standing **rigging** shall comply with the current **Class rules**. Certification is not necessary. The following **rigging** shall be used, and consist of only :

**F.5.1.1** A forestay and one shroud on each side, to support the **mast**. These shall be of steel wire rope, with a minimum diameter of 2 mm. The forestay shall have a minimum length of 3300 mm.

**F.5.1.2** One steel trapeze wire, with a minimum diameter of 2 mm, on each side for the use of one person only. Each trapeze shall be provided with a maximum of :

One handhold, two sheaves, rings or hooks, an elastic cord and one cleat. The two trapezes shall be connected by an elastic cord with a maximum of four fearleads. A length of shockord is allowed to keep the trapeze wires clear of the spreaders. Self-tracking trapeze systems are not allowed.

#### F.5.2 FITTING

**F.5.2.1** Each shroud shall be attached to the shroud plates by means of plates having a row of adjustment holes and pins. No other method of shroud adjustment is permitted.

**F.5.2.2** The forestay shall be attached to the front hole of the stemhead fitting by means of a rope and/or an elastic cord of suitable strength.



## Section G – SAILS

### G.1. MEASUREMENT

G.1.1 Measurement shall be carried out in accordance with the ERS.

G.1.2 Sails shall comply with the **Class rules** in force at the time of **fundamental measurement**.

### G.2 CERTIFICATION

G.2.1 The **official measurer** shall **certify mainsails** and headsails on the port side **tack**, and spinnakers at the **head**. To **certify**, the measurer shall stamp, sign and mention the date. The **certification mark** shall be stamped in black (except for “in house certification”, in this case **the certification mark** shall be in red). The stamp shall be provided by a National Authority. (For information : The mainsail and the spinnaker may be certified without letters and numbers, but they shall comply during racing with .Class rule C.7.3.1)

G.2.2 A National Authority or a National Class Association if delegated may appoint one or more persons as a sailmaker to measure and **certify sails** produced by that manufacturer. A special license for this in house certification shall be awarded for that purpose. (See complementary information regarding "in house certification" in rule G.2.1)

G.2.3 The sails shall carry the sail maker's trade marks and the weight in  $\text{g/m}^2$  of the **body of the sail** shall be indelibly marked near the **head point** by the sailmaker together with the date and his signature or stamp.

### G.2.4 SAILMAKERS

Sailmaker is optional.

## G.3 MAINSAIL

### G.3.1 EMBLEM

The 420 emblem shall be in dark blue, positioned below and adjacent to the top **batten pocket** and conform to the dimensions and requirements mentioned in the diagram with a tolerance of 3 mm (see diagram 14).

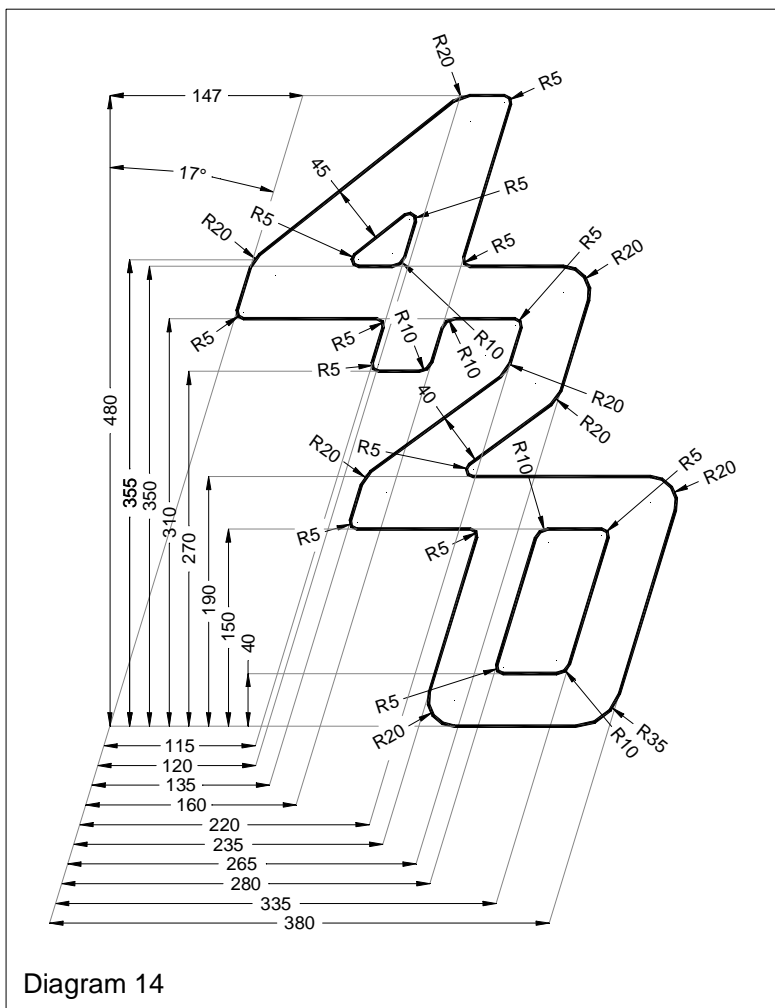

**G.3.2 CONSTRUCTION**

**G.3.2.1** The construction shall be : **Soft sail, single-ply sail.**

**G.3.2.2** The **body of the sail** shall consist of the same white **woven ply** of even weight throughout except for the panel adjacent to the **foot**, which may be of a different **woven ply**. The **ply** fibres shall be of polyester. **Windows** are prohibited.

**G.3.2.3** The weight of the **ply** of the **body of the sail** shall be 150 gr./m<sup>2</sup> minimum.

**G.3.2.4** The following are permitted :

Stritching, glues, **tabling**, tapes, bolt ropes for the **luff** and the **foot**, three corner eyes, one headboard with fixings, one Cunningham eye, a rope for the Cunningham, **batten pocket patches**, **batten pockets** elastics, one **batten pocket** end cap for the top **batten pocket**, one boom slide at the **clew**, tell tales, sail maker's trade mark.

**G.3.3 DIMENSIONS (SEE DIAGRAM 15)**

|                                                                        | Minimum | Maximum |
|------------------------------------------------------------------------|---------|---------|
| Leech length                                                           |         | 5400 mm |
| Quarter width                                                          |         | 2130 mm |
| Half width                                                             |         | 1630 mm |
| Three-quarter width                                                    |         | 995 mm  |
| Upper width at upper leech point<br>( 600 mm of the head point )       |         | 480 mm  |
| Top width                                                              |         | 115 mm  |
| Flutter patches reinforcements                                         |         | 100 mm  |
| Chafing patches reinforcements                                         |         | 900 mm  |
| Primary reinforcements                                                 |         | 300 mm  |
| Secondary reinforcements                                               |         | 900 mm  |
| Batten pocket patches                                                  |         | 150 mm  |
| Prolongation of the centreline of the<br>top batten pocket to the luff | 1420 mm | 1470 mm |
| Distance from the end of the upper<br>Batten pocket to the luff        |         | 20 mm   |
| Inside length of lowermost batten<br>pocket                            |         | 540 mm  |
| Inside length of the two intermediate<br>batten pocket                 |         | 700 mm  |
| Inside batten pockets width                                            |         | 60 mm   |
| Foot boltrope length                                                   | 1920 mm |         |



# MAIN SAIL DIAGRAM

The centres of batten pockets shall be within 50mm of the points shown

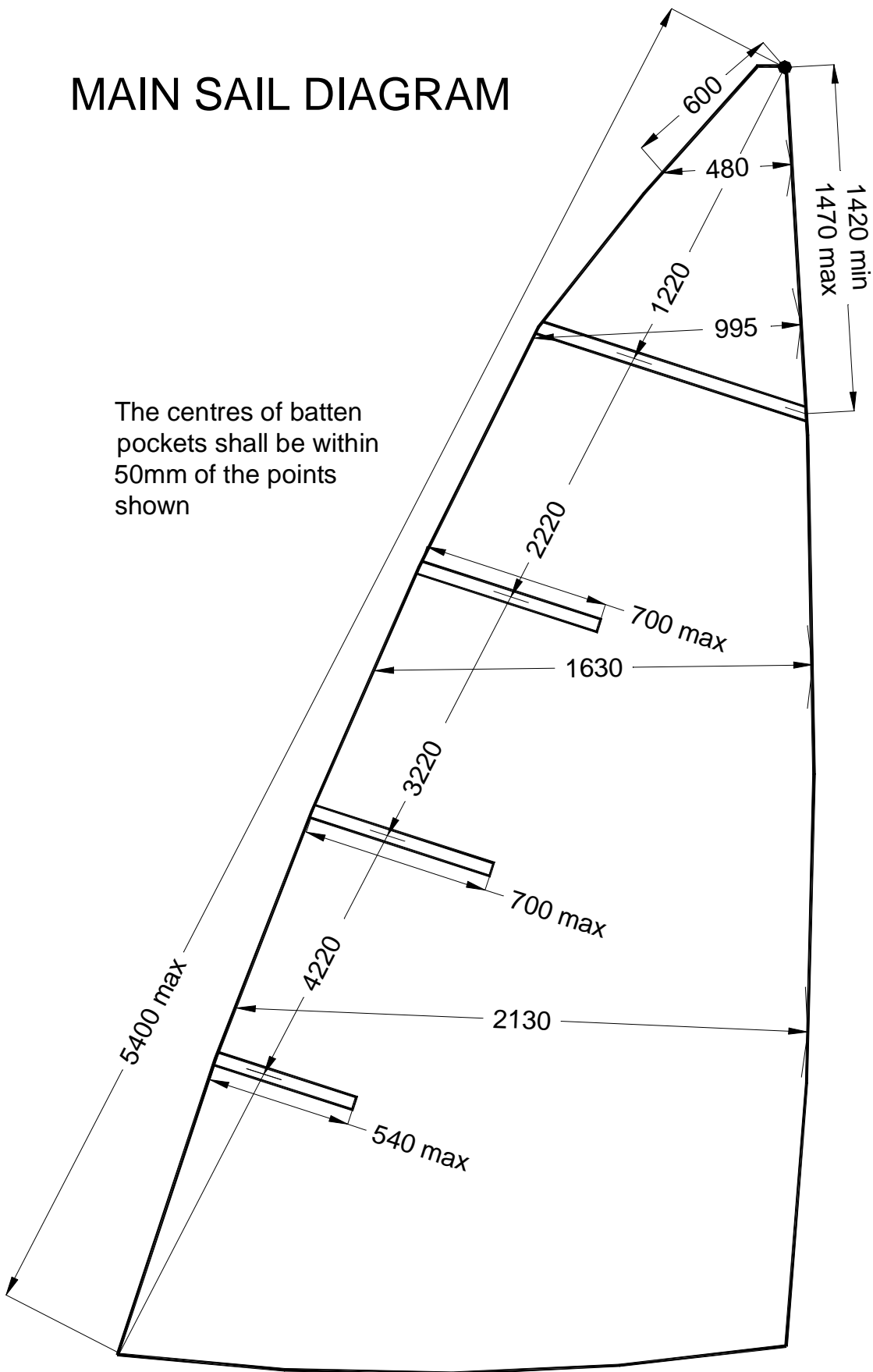

Diagram 15

## G.4 HEADSAIL

### G.4.1 CONSTRUCTION

G.4.1.1 The construction shall be: **Soft sail, single-ply sail.**

G.4.1.2 The **body of the sail** shall consist of the same white woven **ply** of even weight throughout. The **ply** fibres shall be of polyester.

G.4.1.3 The weight of the **ply** of the **body of the sail** shall be 150 gr./m<sup>2</sup> minimum

G.4.1.4 The following are permitted : Stitching, glues, tapes, **tabling**, three corner eyes, one **window** of single layer of unwoven material, tell tales, a rope for the **luff** tension adjustment and one cleat in the **tack** area, a steel wire rope in the **luff**, sailmaker's trade mark

### G.4.2 DIMENSIONS

|                                | Maximum            |
|--------------------------------|--------------------|
| Luff length                    | 3500 mm            |
| Leech length                   | 3200 mm            |
| Foot length                    | 1750 mm            |
| Foot median                    | 3360 mm            |
| Top width                      | 40 mm              |
| flutter patches reinforcements | 100 mm             |
| chafing patches reinforcements | 900 mm             |
| Primary reinforcements         | 300 mm             |
| Secondary reinforcements       | 900 mm             |
| Window area                    | 0,1 m <sup>2</sup> |
| Window dimension               | 540 mm             |

## G.5 SPINNAKER

### G.5.1 CONSTRUCTION

G.5.1.1 The construction shall be : **Soft sail, single-ply sail.** The **sail** shall be symmetrical about its centreline. It shall be made of not more than seven panels and may be of any colour or combination of colours. Except the uppermost panel and the lowest panel, all the cloth shall extend from luff to luff. A centre seam is permitted in the uppermost panel. Not more than three tucks or darts are permitted in the lowest panel, and these shall not touch the **seam** of the next panel nor exceed a maximum length of 450 mm. The colour of any **tabling** and reinforcement is optional.

G.5.1.2 The **body of the sail** shall consist of the same woven **ply** of even weight throughout. The **ply** fibres shall be of polyester or polyamide.

G.5.1.3 The weight of the **ply** of the **body of the sail** shall be 32 gr./m<sup>2</sup> minimum.

G.5.1.4 The following are permitted: Stitching, glues, tapes, corner eyes, tell tales.

### G.5.2 DIMENSIONS

|                          | Maximum |
|--------------------------|---------|
| Leech lengths            | 4000 mm |
| Foot length              | 2220 mm |
| Half width               | 2840 mm |
| Primary reinforcements   | 300 mm  |
| Secondary reinforcements | 900 mm  |

## PART III APPENDICES

---

### OFFICIAL DOCUMENTS :

International 420 Class Rules (March 2003)

Lines plan (Plan de formes) issue B

Building specifications (Drawing N° 5) issue E

International 420 rudder Blade Drawing (April 1986)

International Measurement Form (March 2003)

Effective: 1st MARCH 2003

Previous issue : International 420 Class Rules (March 2002)